

PLAN VIEW

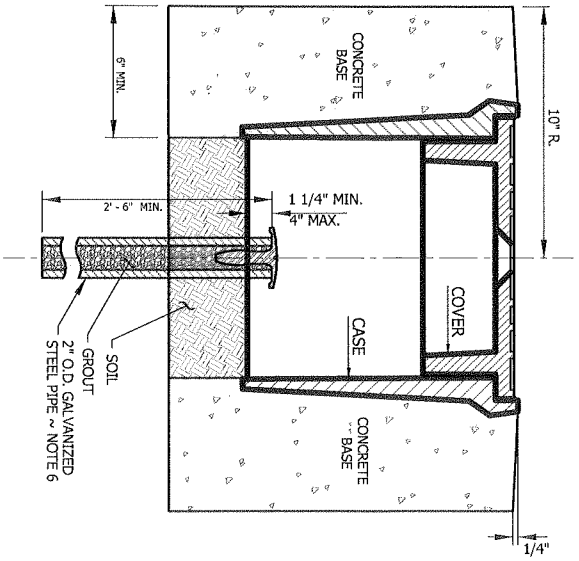

SECTION A-A

RISER RING DIMENSIONS

SIZES	A	B
1 1/2"	1 7/16"	2 7/16"
2"	2"	3"
3"	3"	4"

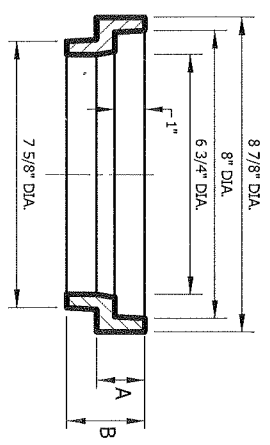

SECTION RISER RING

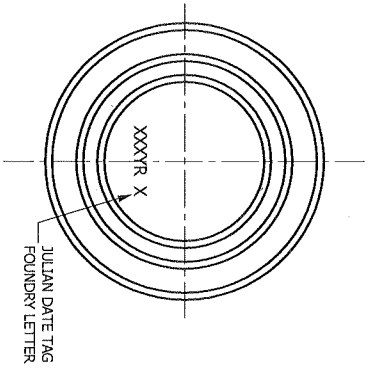

BOTTOM COVER

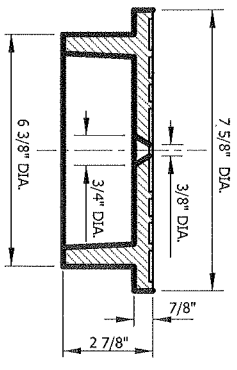

SECTION COVER

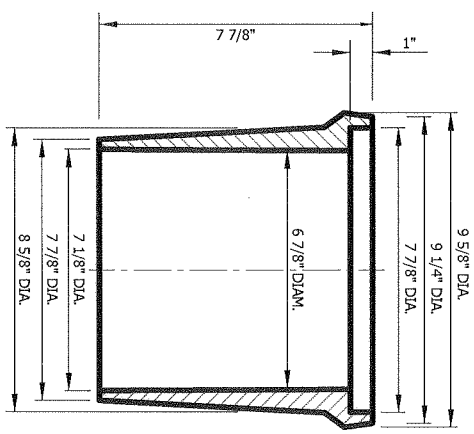

SECTION FRAME SECTION

NOTES:

1. CASTINGS SHALL BE GRAY IRON ASTM A48, AASHTO M 105, CLASS 30.
2. COVER AND SEAT SHALL BE MACHINED FOR PERFECT CONTACT AROUND CIRCUMFERENCE AND FULL WIDTH OF BEARING SURFACE.
3. APPROXIMATE WEIGHTS, STANDARD.
CASE 60 LBS
COVER 19 LBS
TOTAL 79 LBS
4. PAVEMENT SHALL BE ASPHALT CONCRETE OR APPROVED SUBSTITUTE.
5. CONCRETE SHALL BE CLASS 4000.
6. See Island County Standard Plan IC-A-10.20-00 for Monument (brass disc) type to place in 2" O.D. galvanized pipe.

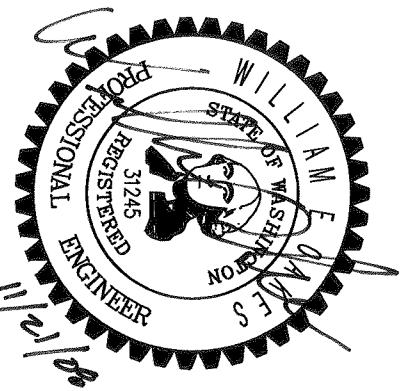

ROADWAY SURVEY MONUMENT CASE AND COVER

ISLAND COUNTY STANDARD PLAN
IC-A-10.30-00

Office of the
ISLAND COUNTY ENGINEER
1 NE 6th Street
Capeville, WA 98223-5000